

The Rutland 913 Windcharger

While you enjoy the breeze of the open sea your Rutland effortlessly keeps the batteries topped up for free!



For pleasure, liveboard and professional sailors the task of maintaining continuous power is made easy with a Rutland 913 Windcharger on board. Essential navigation equipment, lights and the home comforts of a refrigerator, laptop computer and even a hairdryer can be used without the need to run the engine.



Rutland 913 mounted on a pushpit

The Rutland 913 is a popular sight in marinas, thousands are in use worldwide, boat owners like it's clean, aerodynamic lines and its quiet and continuous operation. Without doubt the latest marine model accumulates more energy than any other comparable wind generator available, you'll always see a Rutland spinning in the lightest of breezes!

The Rutland 913 Windcharger's generating capacity is best suited to sail boats over 10m in length and inland boats. Its generous charging capacity in proportion to its compact turning radius make it ideal especially where 2 battery banks are kept on board. Whether liveaboards or weekend sailors it can be conveniently mounted at a height out of reaching distance and in a clear flow of wind.

Modern, durable materials for reliability on the high seas accompany the very high manufacturing standards employed in our ISO9002 certified factory.

When you fit a Rutland Windcharger on board you will experience:

- Direct savings on fuel costs and engine maintenance owing to reduced engine running time
- Security of power for essential appliances on-board, eg. navigation equipment
- Fully charged batteries for engine starting on returning to your boat

Rutland 913 Windchargers are also found on:

- Inland boats
- Caravans
- Roadside Signs
- Streetlighting
- Off-grid CCTV



Rutland 913 mounted on a gantry

Solar Power too!

Windchargers are complemented by solar panels for power generation. Hybrid systems offer a good solution for providing a balanced supply of power throughout the seasons and to take advantage of the various climates around the world. To discuss your power requirements call Marlec, we have been active in renewable energy since 1979 and our expert advice is second to none.

Features & Benefits

- Efficient power conversion – Rutland Windchargers generate greater ampere-hours in real wind conditions than turbines of equal and often larger diameter! That's because between gusts, our unique high inertia alternator designs maintain momentum with a flywheel effect where other units stall. This adds up to more free wind power generated and stored for you.
- Rutland Windchargers are the lowest cost per watt of power generated. Not only is the generator efficient but volume production for our worldwide customers and in-house manufacturing here at Marlec ensures that we deliver a consistently high quality at an affordable cost.
- Our low friction 3-phase alternator gives a smooth and silent output. The low wind speed start up means power is almost continuously produced and certainly in the most typical conditions as well as being powerful in higher winds.
- Rutland 913 turbines are made from computer designed efficient aerofoil blades. They have a unique and positive one way only fit and have been tested to withstand a loading with a safety factor 10 times the turbine's maximum rpm.
- No radiated interference. Complies with EEC Directive 89/336/EEC



Specifications:

Output Graph:

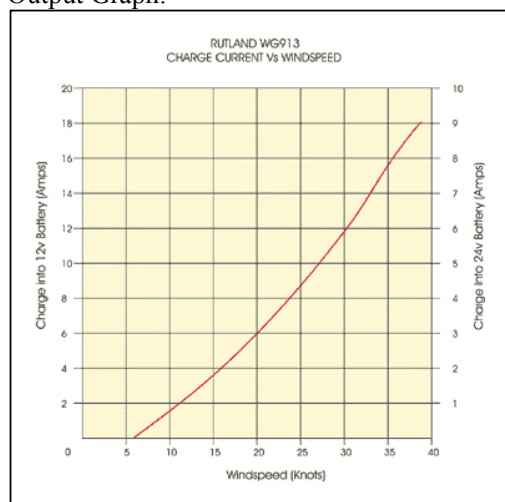

Dimensions:

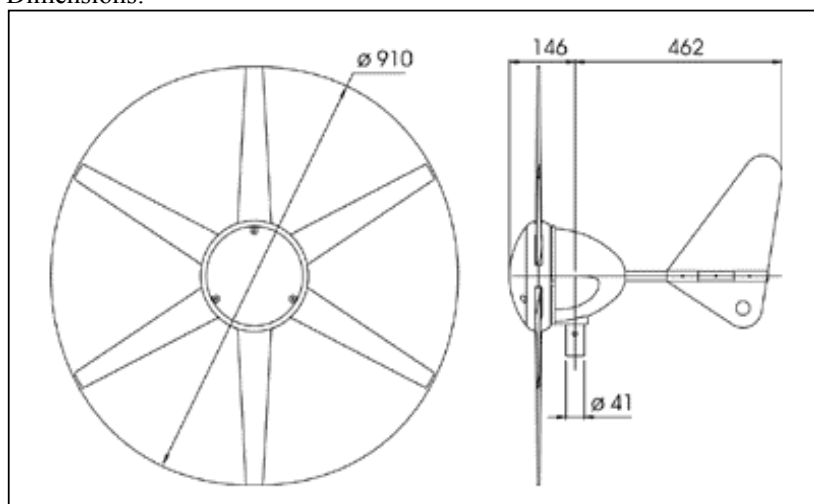

Low wind speed start up of just 5 knots
Generates 90w @ 19 knots, 24w @ 10 knots
Delivers up to 300w

Part Nos: CA-01/15 (12V) CA-01/16 (24V)
Net Weight: 10.5Kg Packing Specifications: 375x375x620mm 13Kg

What else is needed to complete a system?

Marine Mounting Kit – a stainless steel mounting kit with deck bracket is available or a mount may be constructed using a tube of 41mm internal diameter (max external diameter 48mm). Short sections of tube to affix to users own pole are also available.

Land Tower & Rigging Kit – a 6.4m tower made of 3 sections, ground spike and rigging kit for permanent land installation.

Voltage Controller – a choice of HRS913 Regulator to avoid overcharge or the HRDX Controller with digital display, dual charging facility, windcharger and solar panel up to 100W.

Cable – for installations using less than a 20m run of cable we recommend 2.5mm² cable, available per metre from Marlec.

Batteries – Deep cycle or leisure batteries are recommended. Gel and Absorbed Glass Matt ranges are available from Marlec.

For expert system advice and to discuss your power requirements call our technical sales team.



Manufactured in the UK by:

Marlec Eng Co Ltd

Rutland House, Trevithick Rd, Corby, NN17 5XY

Tel: +44 (0)1536 201588 Fax: +44(0)1536 400211

sales@marlec.co.uk www.marlec.co.uk