

SHURflo's REMOTE SOLUTION

Model 9300 Series

SUBMERSIBLE PUMP APPLICATIONS:

- Irrigation
- Livestock Watering
- Remote Homes & Cabins
- Ponds
- Islands



SHURflo's NEW
"Watertite-Gland" Design PAT. PEND.

SHURflo's NEW 9300 Series Solar-Powered Submersible Pump. Rugged, Durable . . . and Built to Last!

SHURflo's 9300 Series Pumps are backed by 25 years of research and engineering experience. Designed to be strong and yet lightweight, these pumps are easily repaired in the field. SHURflo provides a wide-range of parts and kits for ease of rebuilding and repair.

"GLAND" CONNECTOR FEATURES:

- Waterblocked Electrical Connector.
- Impervious gland connection design prevents waterwicking. (Pat. Pend.)
- Quick Disconnect — No splicing necessary.
- Accepts a variety of jacketed cables.

9300 SERIES PUMP FEATURES:

- Strong Construction, yet lightweight (6 lbs.).
- Corrosion-proof housing with stainless-steel fasteners.
- Dry Running capability without pump damage.
- Internal Bypass Feature for pump protection.
- Long-life, 24 VDC Operation.
- Easily repaired in the field.
- 25 years of manufacturing experience with diaphragm pumps.
- State of the art solid diaphragm.



SHURflo®

Model 9300 Series

9300 SUBMERSIBLE PUMP FLOW CHART

TOTAL VERTICAL LIFT		FLOW RATE PER HOUR		SOLAR ARRAY SIZE MINIMUM TOTAL POWER RATING		CURRENT AMPS
FEET	METERS	GAL.	LTR.	WATTS		
20	6.1	111	420	58		1.7
40	12.2	109	413	65		2.0
60	18.3	105	398	78		2.3
80	24.4	103	390	89		2.6
100	30.5	100	379	99		2.9
120	36.6	95	360	104		3.2
140	42.7	93	352	115		3.5
160	48.8	89	337	123		3.8
180	54.9	87	329	135		4.0
200	61.0	84	318	141		4.3
230	70.1	79	300	155		4.6

NOTE: Use of an LCB (Linear Current Booster) Unit is required for optimum performance. Minimum total power rating shows minimum array watts required to perform as shown.

EXPLODED VIEW

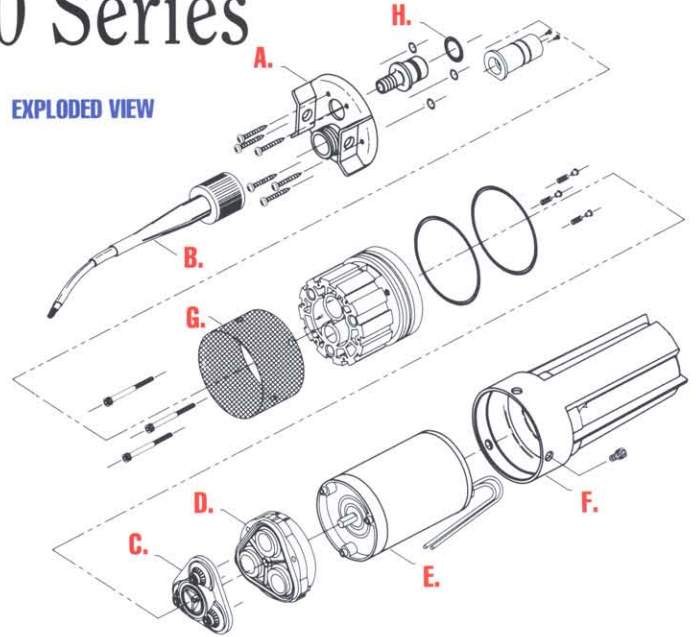

REPLACEMENT PART KITS:

- | | |
|--------------------------------|--------------------------|
| (A) LIFT PLATE | (F) CANISTER KIT |
| (B) CABLE PLUG KIT | (G) FILTER SCREEN KIT |
| (C) VALVE KIT | (H) O-RING KIT |
| (D) LOWER HOUSING ASSEMBLY KIT | (I) TOOL KIT (NOT SHOWN) |
| (E) MOTOR KIT | |

* All kits may consist of more parts than shown in exploded view.

TECHNICAL SPECIFICATIONS:

MODEL NUMBER	9325-043-101*
PUMP DESIGN	Positive Displacement 3 Chamber Diaphragm Pump
CAM MOTOR	3.0 Degree Permanent Magnet, P/N 11-175-00, Thermally Protected
VOLTAGE	24 VDC Nominal
AMPS	4.0 Maximum
INTERNAL BYPASS	105-110 PSI Max. (7.2-7.5 BARS)
MAXIMUM LIFT	230 Feet Maximum (70 Meters)
MAXIMUM SUBMERSION	100 Feet Maximum (30 Meters)
OUTLET PORT	1/2" (12.7mm) Barbed Fitting for 1/2" (12.7mm) I.D. Tubing
INLET MATERIALS	50 Mesh Stainless Steel Screen High Strength Engineered Plastics, Stainless Steel Fasteners
TYPICAL APPLICATIONS	Potable Water Well Pump
NET WEIGHT	6 LBS. (2.7 Kgs.)

*CE Model Available

DIMENSIONS

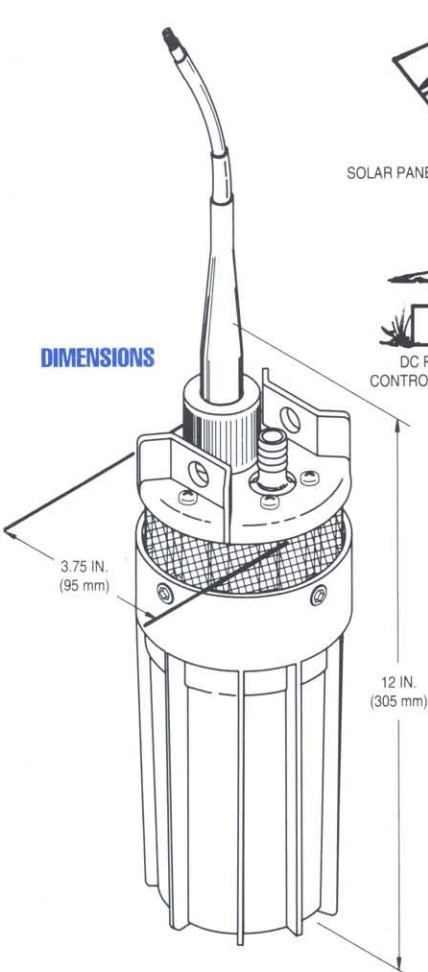

WELL INSTALLATION

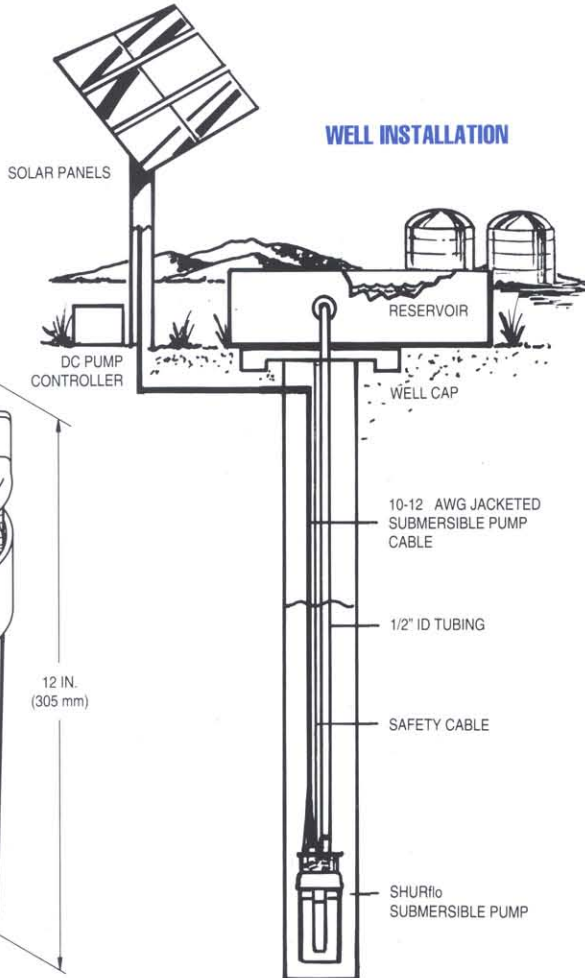

DISTRIBUTED BY:

SHURflo EAST
52748 Park Six Court
Elkhart, Indiana 46514-5427
Phone: (800) 762-8094 • (219) 262-0478
FAX: 219/264-2169

SHURflo HEADQUARTERS *
Mailing Address: 12650 Westminster Avenue
Santa Ana, California 92706-2100
Shipping Address: 12650 Westminster Avenue
Garden Grove, California 92843
Phone: (800) 854-3218 • (714) 554-7709
FAX: (714) 554-8566

SHURflo EUROPE
SHURflo Limited
Unit 5, Sterling Park
Gatwick Road, Crawley
West Sussex, RH10 2QT, UK
Phone: 44-(0) 1293-424000
FAX: 44-(0) 1293-421880

www.shurflo.com

