

# PS600 CS-15-1 formerly PS600 BADU Top12

# PS1800 CS-36-1

# Solar Water Pump Systems

## Manual for Installation, Operation, Maintenance

Thank you for purchasing a LORENTZ PUMP.

**Before you begin** Check the model numbers of all the components of your system, and verify that they are the items that you ordered. Also check against the PUMP specifications and performance charts (end of this manual) to be sure the system is appropriate for your application.

**Please fill in the SYSTEM REPORT** This will be essential information if any problems occur.

Read the manuals of pump end, charger (optionally) and other components used in your system.



**PS600 CS-15-1 was formerly sold under the name PS600 BADU Top12. The product is unchanged.**

### Explanation of Warning Symbols



**WARNING** disregard might lead to injury or damage the installation



**CAUTION** recommended to avoid disfunction or premature ageing of the pump etc.

## 1 Installation

### 1.1 Controllers PS600 and PS1800

- Controlling and monitoring of the motor
- Integrated MPP-Tracking
- LVD protection (low voltage disconnect) for 48V DC and 96V DC batteries
- Check and display the operating states
- Two control inputs for float- or pressure switches, remote control, etc.
- 92% max. efficiency (motor + controller)
- Adjustable maximum RPM setting

### 1.2 Technical Data

see table 1

### 1.3 Mechanical Installation

**Position** If it is outdoors, mount the controller in a vertical position to assure that rain will not enter the box.

**Battery system** Place the controller near the batteries but safely isolated from the battery terminals and from corrosive gases. (Batteries must be in a cool location for best longevity and enclosed for cleanliness and safety.) Connect the battery directly with the + and – Terminal of the controller. Do not use the load terminals of the charge controller as they maybe not strong enough to allow the start current to flow. PS600 and PS1800 controllers have a low voltage function to protect the batteries from deep discharge. An additional charger is only needed for charging the batteries.

### 1.4 Controller Input Wiring



**WARNING TEST THE VOLTAGE** before connecting power to the controller. Voltage (open circuit) must not exceed 150V DC for PS600 and 200V DC for PS1800 controllers. (Even in cloudy weather, the open circuit voltage will be near maximum.)



**WARNING Do not apply a direct connection or an amp meter between + and – when the controller is connected. A short circuit here will cause a strong discharge.**



**WARNING SOLAR-DIRECT systems only** — Do not connect any electrical load to the solar array if it is not part of the LORENTZ Pump system. Connection of a battery charger, active solar tracker controller, electric fence charger, or other load simultaneously with LORENTZ PS systems may “confuse” the controller and prevent proper operation.

Table 1: Technical Data of Controller

System		PS600 CS-15-1	PS1800 CS-36-1
max. power input (Vmp)*	[V DC]	>68	>102, >110 for TDH > 14 m
power max. input current	[A]	unlimited – controller regulates max. power	unlimited – controller regulates max. power
open circuit voltag/Voc	[V DC]	150	200
input voltage battery	[V DC]	48	96
battery low voltage disconnect	[V DC]	44	88
battery restart voltage	[V DC]	52	104
enclosure type		IP 54 (controller), IPX4 (motor)	IP 54 (controller), IPX4 (motor)
ambient temperature	[°C]	–30 to +55	–30 to +55

\*) PV modules at standard test condition: AM = 1.5, E = 1,000W/m<sup>2</sup>, cell temperature: 25 °C

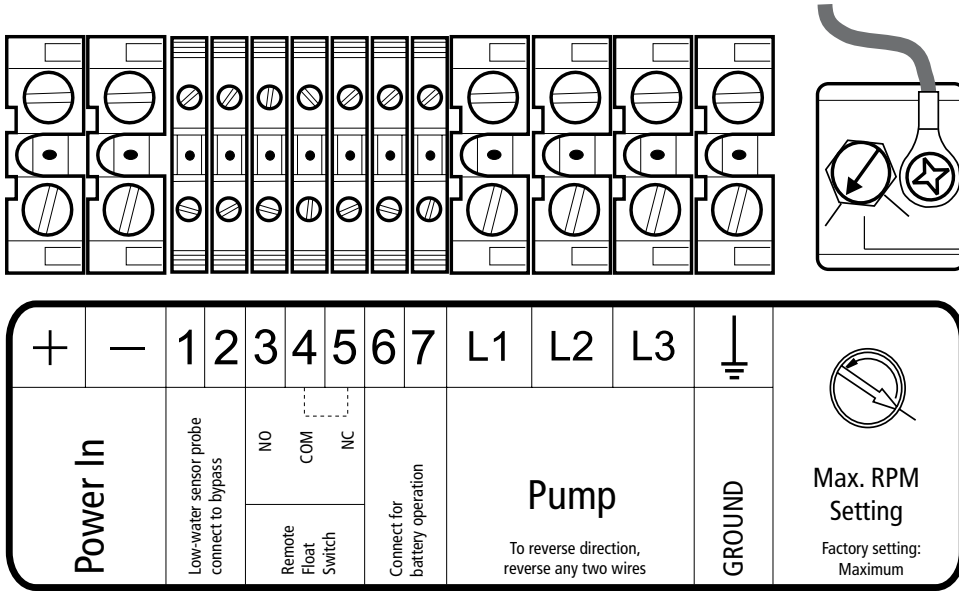

Figure 1: Terminals of PS600 and PS1800 controllers

Terminals inside the PS controller "Max. RPM setting" is at right. To reduce RPM turn counter-clockwise

**1.5 Electrical Installation – Terminals**

See figure 1

**Power IN** For PV-direct systems, a two-pole disconnect switch may be installed between the solar array and the controller. Switch it off to prevent shock and arc burn hazard during installation and maintenance, or if the system will be shut down for the season. For battery systems: Connect the controller directly to the plus and minus terminals of the battery. Do not connect to the load terminals of the charger as they may be not strong enough to provide the starting current. A 20A slow blow fuse must be installed between the controller and the battery.

**Ground** Connect the ground wire to the ground connection in the controller. Grounding helps to prevent shock hazard if there is a fault in the motor.

**L1 – L2 – L3** ECDRIVE requires four-conductor (four-wire) cable between the controller and the motor. The three wires L1, L2 and L3 carry power. The fourth wire carries ground. To reverse direction of rotation reverse any two wires.

**No. 1 and 2** In order to protect the pump from being damaged by dry running connect one well probe cable to each terminal. If dry run protection is not needed, short cut these two terminals.

**No. 3, 4 and 5** Connect any kind of external switch (NO or NC type) for remote control of the controller. In case no switch is used the terminals No. 4 and 5 have to be connected with a short cable (factory setting). In case a NO-switch is used (connected to the terminals No. 3 and 4) the short cable (connecting the terminals No. 4 and 5) must remain installed.

**No. 6 and 7** Connect these two terminals to switch the controller to battery mode. The motor will be switched OFF by the controller if the input voltage is below 44V DC (PS600) or 88V DC (PS1800) respectively in order to protect the battery. If the battery voltage increases to 52VDC (PS600) or 104VDC (PS1800) respectively, the motor will be switched ON automatically.

**1.6 Battery-based Systems**

**Only PS600 and PS1800 pump systems can be operated from batteries.**

**Short circuit protection** Install a fuse or circuit breaker near the power source. Use a 20A circuit breaker or a time-delay (slow blow) fuse. The purpose of this protection is for safety in case of a wiring fault, and to provide a means of disconnect when installing or maintaining the system. PS600 and PS1800 controllers have electronic over-current protection against motor overload.

**Low-voltage disconnect function** Lead-acid batteries can be permanently damaged by over-discharge when the voltage falls below a critical point. To prevent this, the PS battery-system controller will turn off at low voltage, and turn back on only after the battery has recovered significantly.

The set points are:

System	Voltage	OFF	ON
PS600CS-15-1	48VDC	44VDC	52VDC
PS1800CS-36-1	96VDC	88VDC	104VDC

A controller in disconnect mode can be reset manually by turning off/on, but it will quickly disconnect again if the battery is not gaining a substantial recharge.

**1.7 Wire Sizing**

**Wire sizing for the DC circuit** Wire must be sized for no more than 5% voltage drop at 20A (starting).

Refer to a wire sizing chart for 48VDC (PS600) or 96VDC (PS1800), or follow these examples:

**PV-direct systems**

AWG #10 wire to maximum distance of 30 ft  
Metric: 4 mm<sup>2</sup> to max. 20m

**Battery systems**

AWG #10 wire to maximum distance of 30 ft  
Metric: 4 mm<sup>2</sup> to max. 15m

**GREATER LENGTHS** For each increase by 50 %, use next larger wire size

## 2 Operating the Pump

This explains the function of the switch and the indicator lights on the pump controller.

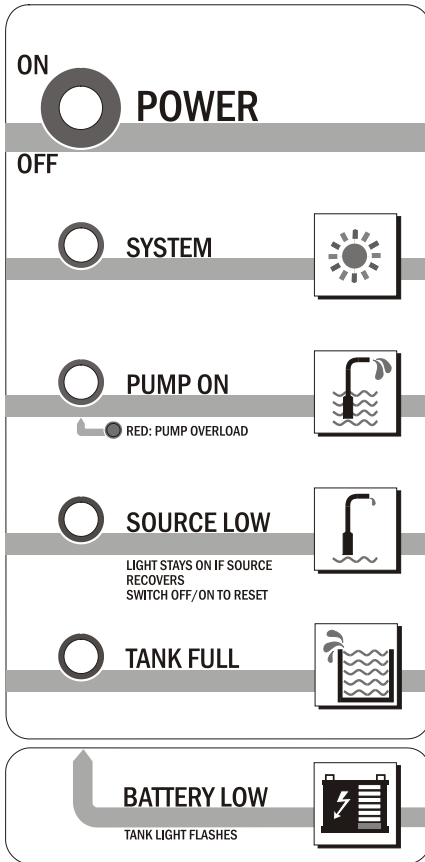

### SWITCH: POWER ON/OFF

When switched off/on during operation, it resets all system logic.

### INDICATOR LIGHTS

#### SYSTEM (green)

The controller is switched on and the power source is present. In low-power conditions, the light may show even if there is not enough power to run the pump.

#### PUMP ON (green)

Motor is turning. Sequence of flashing indicates pump speed. See below sequence

#### PUMP OVERLOAD (green changes to red)

#### SOURCE LOW (red)

The water source dropped below the level of the low-water probe. After the water level recovers, the pump will restart, but this light will slowly flash until the sun goes down, power is interrupted, or the POWER switch is reset. This indicates that the water source ran low at least once since the previous off/on cycle.

#### TANK FULL (red)

Pump is turned off by action of the remote float switch (or pressure switch or manual switch, whichever is wired to the "remote float switch" terminals.

#### BATTERY LOW (tank light flashes)

**Battery systems only** – battery voltage fell to 44VDC (PS600) or 88VDC (PS1800), and has not yet recovered to 52VDC (PS600) or 104VDC (PS1800).

#### RPM indication

Pump speed can be read off by the flashing sequence of the Pump ON LED.

Indication	RPM
LED ON	> 900
one flash	> 1,200
two flashes	> 1,600
three flashes	> 2,000
four flashes	> 2,400
five flashes	> 2,800

### Starting the pump

Be sure there is not a closed valve or other obstruction in the water line.

Fill the pump with clean water until the water level reaches the inlet connection. Coat the O-ring seal with vaseline, close the lid by hand and make sure that it is well in the housing groove. Otherwise the pump will prime insufficiently or not at all.



**NEVER LET THE PUMP RUN DRY, NOT EVEN FOR THE PURPOSE OF CHECKING THE DIRECTION OF ROTATION!**

Switch on the array disconnect switch, and toggle the power switch on the controller. It is normal to leave the switches on at all times, unless you desire to have the system off.

A solar-direct pump should start under the following conditions

1. clear sunshine at an angle of about 20° or more from the surface of the solar array
2. cloudy conditions, if the sunshine is bright enough to cast some shadow
3. low-water probe submersed in the water source (or bypassed in the controller) – Water-Low light OFF
4. full-tank float switch is not responding to a full tank – Tank-Full light OFF
5. battery system only – voltage is higher than the low-voltage disconnect point of 44VDC (PS600) or 88VDC (PS1800).

**When sunshine is insufficient** When sunshine on the array is present, but too weak for the pump to run, it will attempt to start about every 120 seconds. During each attempt, you will see the PUMP ON light come on.

When pump runs slowly (PUMP ON) under weak sun conditions the pump may spin without lifting water all the way to the outlet. This is normal.

**When pump stops from a sudden shadow on the solar array** If a shadow suddenly passes over the array, like if you walk in front of it, the controller will lose track of the input voltage. This does NOT indicate a problem. The pump will attempt to restart after the normal delay.

#### Time delays

1. After pump stops due to insufficient sunshine – 120 seconds
2. After full-tank float switch resets – 2 to 3 seconds
3. After low-water probe regains contact with water in the source – 20 minutes but the indicator light will slowly flash for the rest of the solar day, or until power is disrupted or the controller is turned off/on.
4. Battery systems – after low voltage disconnect point is reached, delay to stop pump – a few SECONDS. After voltage recovers, delay to re-connect – a few SECONDS

**To force a quick start** To test or observe the system, you can bypass the normal time delays. Switch the POWER switch off then on again. The pump should start immediately if sufficient power is present.

### 3 Automatic Control For Full-Tank Shutoff

We recommend the use of a float switch or other means to prevent overflow of your tank. This will stop the pump when the tank is full, then reset when the level drops. This conserves ground water, prevents overflow, and eliminates unnecessary pump wear. PS controllers allow the use of small signal cable to a remote float switch, even if the tank is a long distance away.

#### Float switch requirements

1. A switch must be used, not wet electrodes.
2. The preferred system requires a float switch to MAKE contact on rise to turn the pump OFF. This is called "normally open" (N.O.). It may be commercially labeled as a "pump down" switch, but here it works in reverse, to allow pumping up.

#### Float switch cable requirements

1. Two wires are needed.
2. Minimum wire size #18 AWG (1mm<sup>2</sup>). This is good for a distance as far as 2,000 feet (600 m).
3. The cable must be suitable for its environment.
4. If it must run a long distance, use twisted-pair shielded cable to reduce the chance of damage from lightning-induced surge.

**Grounding shielded float switch cable** If you use shielded cable, connect the shield to ground AT THE CONTROLLER ONLY. DO NOT ground the shield at the float switch. This will reduce surges induced by nearby lightning.

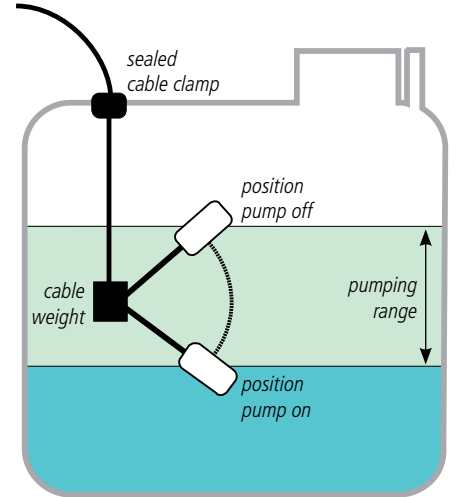

**Wiring to the controller** The controller offers two options for connection of a remote switch. These allow the use of either a "normally open" (N.O.) or a "normally closed" (N.C.) switch. "Normal" refers to the status of the contacts when the switch is DOWN and calling for water.

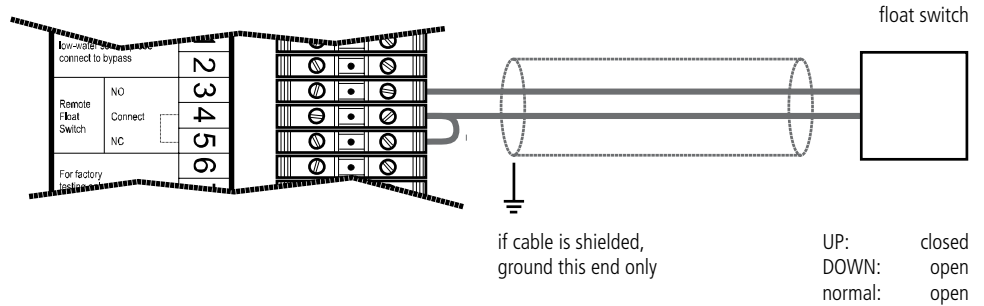

#### Wiring a "normally closed/reverse action switch"

Connect the switch to terminals 4 and 5. Closing (connecting) the switch turns the pump ON

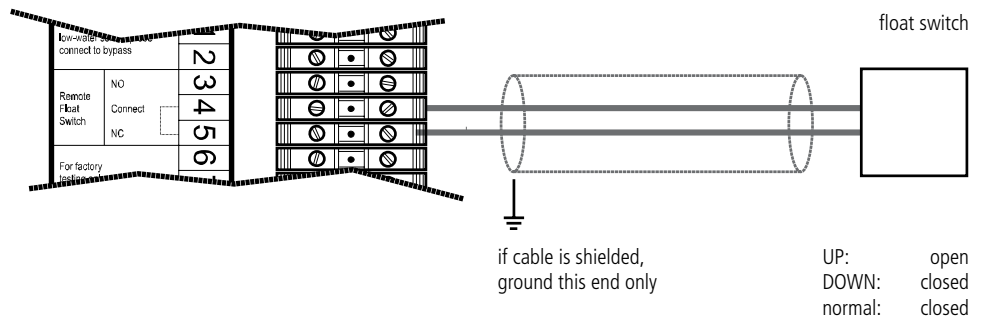

### 4 Maintenance

**Controller** The controller's electronic has no moving or wearing parts. It requires no maintenance. There are rubber plugs to seal at the bottom, unused conduit holes. Inspect them to insure that the controller is sealed from moisture, insects, etc. Check that mounting and conduit hardware is tight.

**Motor** The motor requires no maintenance. It has no brushes or other frequently wearing parts.

**Pump end** The pump mechanism (pump end) is lubricated only by water and requires no maintenance. It may wear after some years, especially if there are abrasive solids in the water. If sand accumulates in the storage tank or pipes as a result of normal pumping, it is best to take periodic measurement of the pump's performance. A worn pump end can be replaced in the field.

### 5 System Wiring Diagram for Solar-direct (non-battery) Systems

PS600 CS-15-1 system typically uses 4 to 6 PV modules with a nominal voltage of 12VDC and maximum power voltage (Vmp)\* of approx. 17VDC in series. Your system may vary in the number, voltage, and configuration of PV modules. The following example for PS600 CS-15-1 uses four 12VDC PV modules.

PS1800 CS-36-1 systems typically use 6 to 8 PV modules with a nominal voltage of 12VDC and maximum power voltage (Vmp)\* of approx. 17VDC in series.



Before connecting the array to the controller measure the open-circuit voltage. It must be within a range of 75–135VDC (PS600) or 115–180VDC (PS1800).

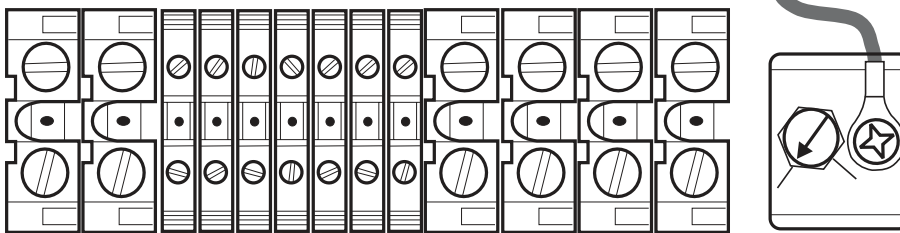
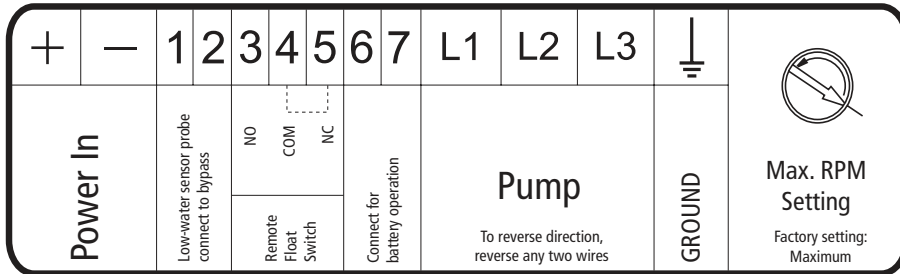

**Float switch (optional)**

Float Switch Kit makes contact on rise to stop pump. Connect terminals 3 (NO) and 4 (COM) and connect terminals 4 and 5 with jumper wire. If you are not using a float switch, install a jumper wire between terminals 4 and 5

**Low water probe (optional)**

If you are not using the low-water probe, install a jumper wire between terminals 1 and 2

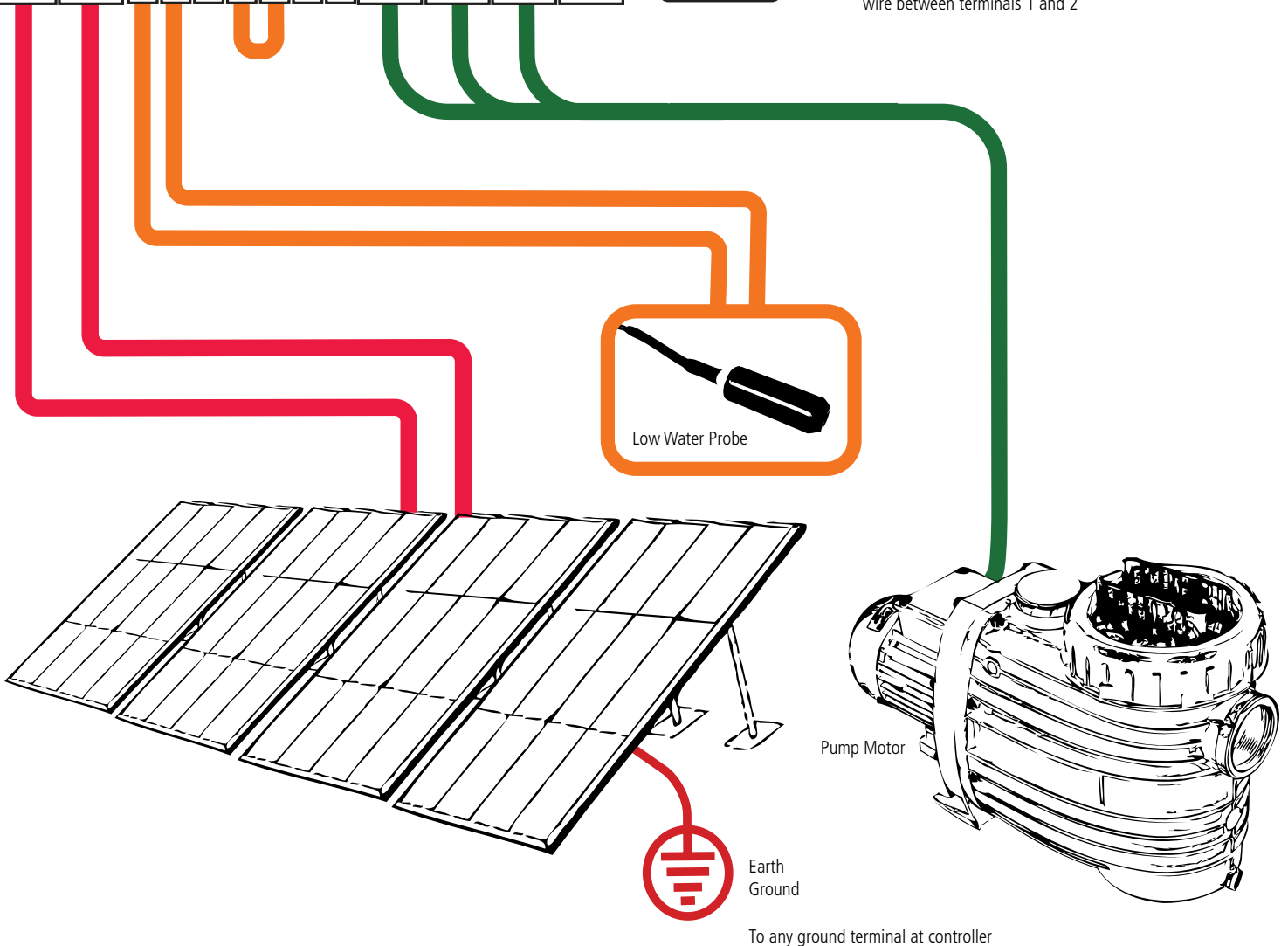

\*) PV modules at standard test condition: AM = 1.5, E = 1,000W/m<sup>2</sup>, cell temperature: 25 °C



Check manual of PV module for specific grounding requirements.

## 6 Trouble Shooting

### Please read this section before calling for help.

If you call for help, please refer to the model and serial numbers.

### If The Pump Does Not Run

Most problems are caused by wrong connections (in a new installation) or failed connections, especially where a wire is not secure and falls out of a terminal. The System ON light will indicate that system is switched on and connected to the controller. It indicates that VOLTAGE is present but (in a solar-direct system) there may not be sufficient power to start the pump. It should attempt to start at intervals of 120 seconds.

### Pump attempts to start every 120 seconds but doesn't run

The controller makes a slight noise as it tries to start the pump. The pump will start to turn or just vibrate a little.

1. There may be insufficient power reaching the controller. A solar-direct (non-battery) system should start if there is enough sun to cast a slight shadow. A battery system should start if the supply voltage is higher than 44VDC (PS600) or 88VDC (PS1800).
2. If the pump was recently connected (or reconnected) to the controller, it may be running in reverse direction due to wiring error.
3. If the motor shaft only vibrates and will not turn, it may be getting power on only two of the three motor wires. This will happen if there is a broken connection or if you accidentally exchanged one of the power wires with the ground wire.
4. The pump or pipe may be packed with mud, clay, sand or debris.

**PUMP OVERLOAD (PUMP ON light shows red instead of green)** The system has shut off due to an overload. This can happen if the motor or pump is blocked or very difficult to turn and is drawing excessive current (hard to turn). Overload detection requires at least 250W (for PS600) and 500W (for PS1800) output of the PV array. This can be caused by a high concentration of solids in the pump. The controller will make 3 start attempts before shutting down the system. The System ON LED will be OFF and the red OVERLOAD LED ON. The system will not reset until the ON / OFF switch is turned OFF and ON again.

### Inspect the solar array

1. Is it facing the sun?
2. Is there a partial shadow on the array? If only 10 % of the array is shadowed, it can stop the pump!

### Inspect all wires and connections

1. Look carefully for improper wiring (especially in a new installation).
2. Make a visual inspection of the condition of the wires and connections. Wires are often chewed by animals if they are not enclosed in conduit (pipe).
3. Pull wires with your hands to check for failed connections.

### Inspect the controller

1. Remove the screws from the bottom plate of the controller. Move the plate downward (or the controller upward) to reveal the terminal block where the wires connect.
2. First, check for a burnt smell. This will indicate a failure of the electronics. Look for burnt wires, bits of black debris, and any other signs of lightning damage.
3. Inspect the grounding wires and connections! Most controller failures are caused by an induced surge from nearby lightning where the system is NOT effectively grounded. Ground connections must be properly made and free of corrosion.

### Check the low-water probe system

If the controller indicates "SOURCE LOW" when the pump is in the water, inspect the low-water probe system. The probe is mounted on, or near the pump. If inspection is not feasible, you can bypass the probe or test it electrically.

### Check the full-tank float switch

If the controller indicates "TANK FULL" when the storage tank is not full, inspect the float switch system. If your system has a float switch, it will be mounted in the tank. If inspection is not feasible, you can bypass the switch or test it electrically.

### Force a quick start

If you restore a connection or bypass the probe or float switch, there is no need to wait for the normal time delay. Switch the on/off switch (or the power source) off then on again. The pump should start immediately if sufficient power is present.

If the pump responds to the bypass tests above but not to the float switch, the wires may be shorted (touching each other) or open (broken), or the switch may be stuck with debris, or out of its correct position.

1. Is the solar array receiving shadow-free light? (It only takes a small shadow to stop it.) Is it oriented properly toward the south, and tilted at the proper angle?
2. Be sure you have the right pump for the total lift that is required.
3. Be sure all wire and pipe runs are sized adequately for the distance. Refer to wire sizing in the pump sizing table.
4. Inspect and test the solar array circuit and the controller output, as above. Write down your measurements.
5. There may be a leak in the pipe from the pump.
6. There is a "max. RPM" adjustment in the controller. It may have been set to reduce the flow as low as 30%.

## 7 Performance Charts

### 7.1 PS600 CS-15-1: Solar-direct Operation

PV generator: max. power voltage (Vmp)\*: > 68VDC, open circuit voltage (Voc): max. 150VDC, nominal voltage 48–72VDC

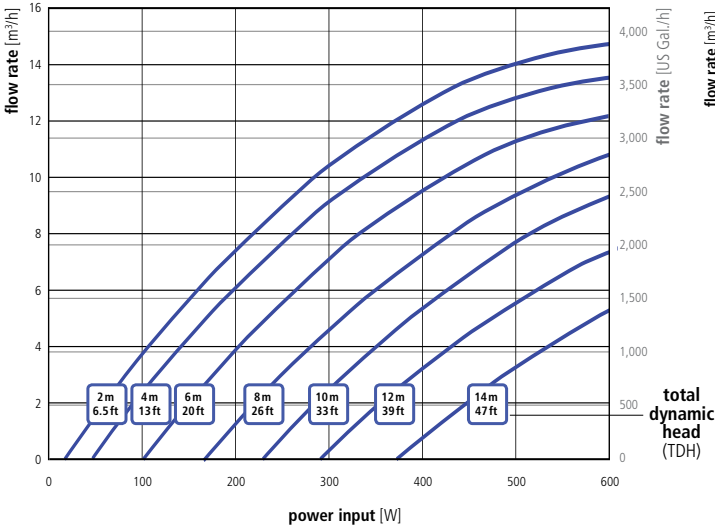

\*) PV modules at standard test condition: AM = 1.5, E = 1,000W/m², cell temperature: 25 °C

### 7.2 PS1800 CS-36-1: Solar-direct Operation

PV generator: max. power voltage (Vmp)\*: > 102VDC (> 110VDC for TDH > 14 m), open circuit voltage (Voc): max. 200VDC, nominal voltage 72–96VDC (> 84–96VDC for TDH > 14 m)

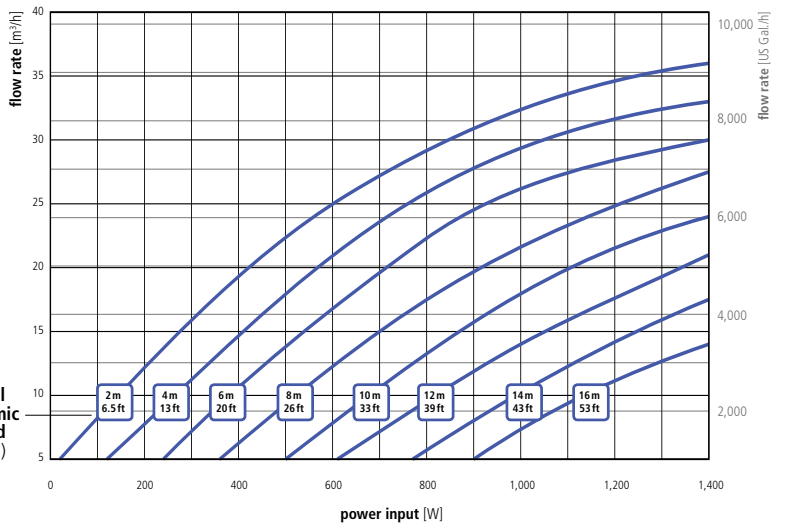

### 7.3 PS600 CS-15-1: Battery Operation

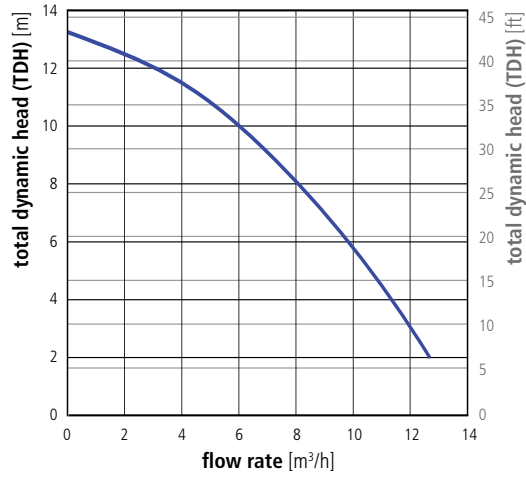
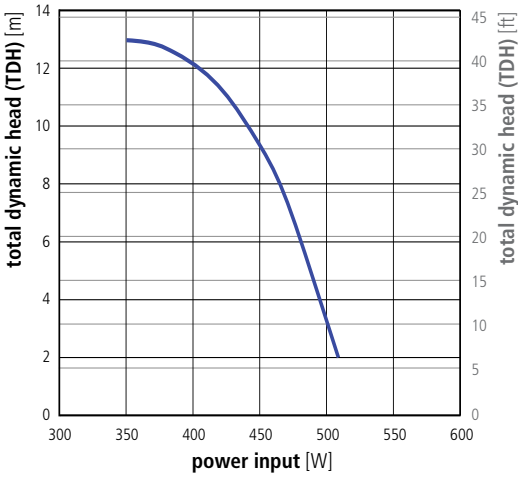

### 7.4 PS1800 CS-36-1: Battery Operation

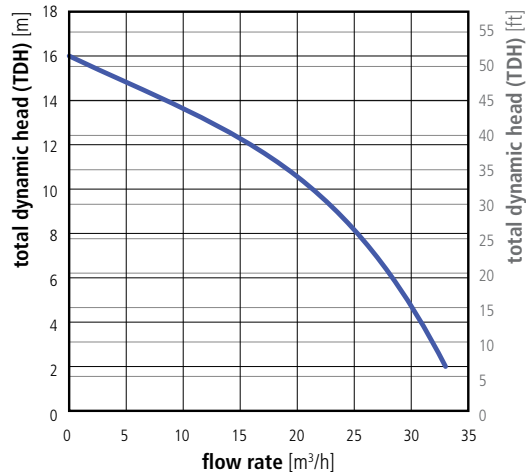
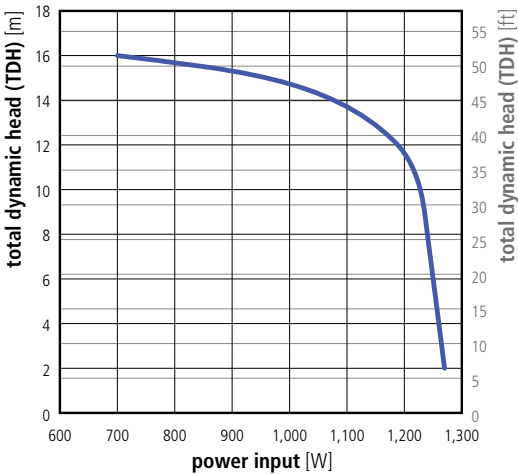

## System Report

### System and Components

Date of purchase

Dealer  
(full contact details)

### System

System  PS600  PS1800

Controller serial #

Motor serial #

### PV generator

PV modules

PV module brand

PV module model

Vmp  VDC

Voc  VDC

Quantity

wired  serial  parallel

### Battery system

Battery system  yes  no

If yes:

System voltage  VDC

Capacity of battery bank  Ah

Type of batteries

Quantity

wired  serial  parallel

### Installation

Installation date

Installer  
(full contact details)

Head  m | ft

Suction

Suction head  m | ft

Max. suction head (drawdown)  m | ft

Positive suction head  m | ft

Max. positive suction head (drawdown)  m | ft

Suction pipe

Size  mm<sup>2</sup> | in

Type

Length  m | ft

Drop pipe

Size  mm<sup>2</sup> | in

Type

Length  m | ft

Pump cable

Wire size  mm<sup>2</sup> | AWG

Length (Controller to pump)  m | ft

### Max. RPM control

Factory setting is max.  yes  no

If this setting was reduced, enter setting here: